



P2EXP User Guide

Apply for P2X Series/FIP15G Plus IP Phone

Version 1.1.0

Nov. 2024

Copyright

Copyright © 2020 Flyingvoice Network Technology CO., LTD.

Copyright © 2020 Flyingvoice Network Technology CO., LTD. All rights reserved. No parts of this publication may be reproduced or transmitted in any form or by any means, electronic or mechanical, photocopying, recording, or otherwise, for any purpose, without the express written permission of Flyingvoice Network Technology CO., LTD. Under the law, reproducing includes translating into another language or format.

When this publication is made available on media, Flyingvoice Network Technology CO., LTD. gives its consent to downloading and printing copies of the content provided in this file only for private use but not for redistribution. No parts of this publication may be subject to alteration, modification or commercial use. Flyingvoice Network Technology CO., LTD. will not be liable for any damages arising from use of an illegally modified or altered publication.

Trademark

Flyingvoice®, the logo and the name and marks are trademark of Flyingvoice Network Technology CO., LTD, which are registered legally in China, the United States, EU (European Union) and other countries.

All other trademarks belong to their respective owners. Without Flyingvoice's express written permission, the recipient shall not reproduce or transmit any portion thereof in any form or by any means, with any purpose other than personal use.

Warranty

1. Warranty

THE SPECIFICATIONS AND INFORMATION REGARDING THE PRODUCTS IN THIS GUIDE ARE SUBJECT TO CHANGE WITHOUT NOTICE. ALL STATEMENTS, INFORMATION, AND RECOMMENDATIONS IN THIS GUIDE ARE BELIEVED TO BE ACCURATE AND PRESENTED WITHOUT WARRANTY OF ANY KIND, EXPRESS OR IMPLIED. USERS MUST TAKE FULL RESPONSIBILITY FOR THEIR APPLICATION OF PRODUCTS.

2. Disclaimer

FLYINGVOICE NETWORK TECHNOLOGY CO., LTD. MAKES NO WARRANTY OF ANY KIND WITH REGARD TO THIS GUIDE, INCLUDING, BUT NOT LIMITED TO, THE IMPLIED WARRANTIES OF MERCHANTABILITY AND FITNESS FOR A

PARTICULAR PURPOSE. FLYINGVOICE Network Technology CO., LTD. shall not be liable for errors contained herein nor for incidental or consequential damages in connection with the furnishing, performance, or use of this guide.

3. Limitation of Liability

Flyingvoice and/or its respective suppliers are not responsible for the suitability of the information contained in this document for any reason. The information is provided "as is", and Flyingvoice does not provide any warranty and is subject to change without notice. All risks other than risks caused by use of the information are borne by the recipient. In no event, even if Flyingvoice has been suggested the occurrence of damages that are direct, consequential, incidental, special, punitive or whatsoever (Including but not limited to loss of business profit, business interruption or loss of business information), shall not be liable for these damages.

End User License Agreement

This End User License Agreement ("EULA") is a legal agreement between you and Flyingvoice. By installing, copying or otherwise using the Products, you: (1) agree to be bounded by the terms of this EULA, (2) you are the owner or an authorized user of the device, and (3) you represent and warrant that you have the right, authority and capacity to enter into this agreement and to abide by all its terms and conditions, just as if you had signed it. The EULA for this product is available on the Flyingvoice Support page for the product.

Patent Information

China, the United States, EU (European Union) and other countries are protecting one or more patents of accompanying products and/or patents being applied by Flyingvoice.

Technical Support

Visit www.flyingvoice.com for product documents and FAQ, or contact Flyingvoice by email at support@flyingvoice.com. We'll get you the help you need.

Declaration of Conformity

Part 15 FCC Rules

FCC STATEMENT:

This device complies with Part 15 of the FCC Rules. Operation is subject to the following three conditions:

- This device may not cause harmful interference
- This device must accept any interference received, including interference that may cause undesired operation.

Warning: Changes or modifications not expressly approved by the party responsible for compliance could void the user's authority to operate the equipment.

NOTE: This equipment has been tested and found to comply with the limits of a Class B digital device, pursuant to Part 15 of the FCC Rules. These limits are designed to provide reasonable protection against harmful interference in a residential installation. This equipment generates, uses and can radiate radio frequency energy, and if not installed and used in accordance with the instructions, may cause harmful interference to radio or television reception, which can be determined by turning the equipment off and on, the user is encouraged to try to correct the interference by one or more of the following measures:

- Reorient or relocate the receiving antenna.
- Increase the separation between the equipment and receiver.
- Connect the equipment into an outlet on a circuit different from that to which the receiver is connected.
- Consult the dealer or an experienced radio/TV technician for help.

FCC Radiation Exposure Statement:

This equipment complies with FCC radiation exposure limits set forth for an uncontrolled environment. This equipment should be installed and operated with minimum distance 20cm between the radiator & your body.

CE

Manufacturer: Flyingvoice Network Technology Co., Ltd.

Address: 1801-1802, Building 1, Chongwen Park, Nanshan Zhiyuan, Nanshan District, Shenzhen, China

Hereby, Flyingvoice Network Technology Co., Ltd. declares that this device is in compliance with the essential requirements and other relevant provisions of Directive 2014/53/EU

A copy of the declaration of conformity can be obtained with this user manual; this product is not restricted in the EU.

Safety warning and Attentions

If use adapter, adapter must be comply 2014/30/EU Directive.

Adapter Caution: Adapter shall be installed near the equipment and shall be easily accessible.

Do not store or use your product in temperatures higher than 50°C.

RF Exposure Statement

The distance between user and products should be no less than 20cm.

GNU GPL INFORMATION

Flyingvoice phone firmware contains third-party software under the GNU General Public License (GPL). Flyingvoice uses software under the specific terms of the GPL. Please refer to the GPL for the exact terms and conditions of the license.

The original GPL license, source code of components licensed under GPL and used in Flyingvoice products can be downloaded online:

https://www.flyingvoice.com/soft_GPL.aspx

Risk Warning Statement

This risk warning statement contains a summary of external network servers that FVUI will access under its factory settings in order to obtain necessary service support. If you want to prohibit these accesses based on security considerations, you can disable them through the WEB management page.

Number	Server Domain Name	Description	Factory Setting
1	https://prv3.flyingvoice.net:442	Flyingvoice Provision web management configuration server	Enable
2	https://prv4.flyingvoice.net	Flyingvoice Provision web management backup server	Enable
3	pool.ntp.org/cn.pool.ntp.org	NTP server	Enable
4	https://rps.flyingvoice.net	Flyingvoice Provision redirect server	Enable

Catalog

About This Guide.....	3
Getting Started	4
Physical Features.....	4
Icon Instructions	5
LED Instructions	7
Page Key LED.....	8
Ext Key LED.....	8
Installation	9
Startup interface	10
Configure P2EXP Expansion Module	10
SpeedDial	11
BLF	11
BLF List.....	12
Line	12
Voice Mail.....	13
Intercom	13
DTMF	13
DND	14
Record	14
URL Record	15
Multicast Paging	15
Paging List	15
URL Request.....	16
Pickup	16
Group Pickup	17
Call Park	17
Retrieve Park	17
Private Hold	18

History.....	18
Directory.....	18
Local Group	18
XML Group.....	19
XML Browser.....	19
LDAP	20
Corporate Directory	20
Menu.....	20
Status.....	21
Hot Desking	21
Resetting the P2EXP Expansion Module	22
Reset the P2EXP Expansion Module via the phone web interface.....	22
Reset the P2EXP and Host phone via the Phone UI.....	22

About This Guide

Thank you for choosing Flyingvoice P2EXP Color-screen Expansion Module, which delivers the industry's leading HD audio quality and a wide range of business telephony features, such as Call Hold, Call Transfer, Busy Lamp Field, Call Recording, Paging and Conference over an IP network. Meanwhile, it features a compact appearance, robust performance and cost efficiency for daily desktop voice communications.

This guide provides everything you need to quickly use your new Phone Accessories. Firstly, verify with your system administrator that the IP network is ready for phone configuration. Also be sure to read the Quick Start Guide which can be found in your phone package before you set up and use the IP phone. As you read this guide, keep in mind that some features are configurable by your system administrator or determined by your phone environment. As a result, some features may not be enabled or may operate differently on your phone. Additionally, the examples and graphics in this guide may not directly reflect what is displayed or is available on your phone screen.

Related Documentation

The following types of related documents are available on each page:

- P2EXP Datasheet
- P2EXP Quick Guide

You can also refer to the website www.flyingvoice.com to learn more about the features of the IP phones.

Getting Started

It is recommended that you familiarize yourself with the hardware introduction and user interface of the P2EXP Expansion Module before using the expansion module.

Topics

[Physical Features](#)

[Icon Instructions](#)

[LED Instructions](#)

[Installation](#)

[Startup interface](#)

For more information and support, please contact the Administrator.

Physical Features

The main hardware components of the P2EXP Color-screen Expansion Module are shown below:

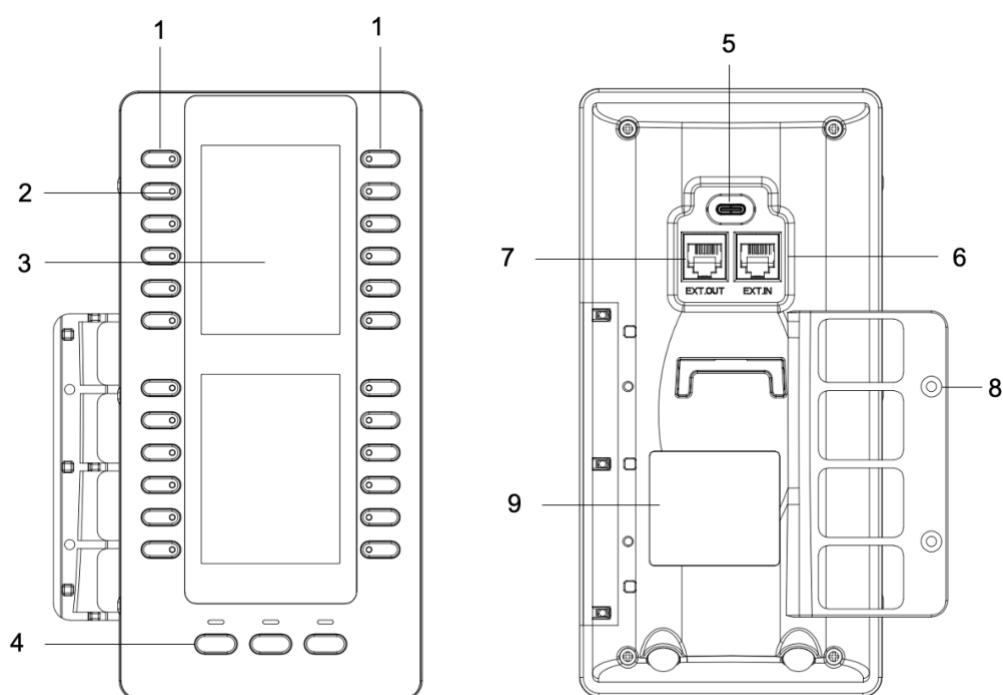

The main hardware components of the P2EXP are described below:

















NO	Item	Description
----	------	-------------







01	Ext Key	Extension keys for configuring multiple function.
02	LED Instructions	Indicates the status of the extension key function. For more information, refer to LED Instructions .
03	Color LCD Screen	Shows key feature label and key feature icon. For more information, refer to Icon Instructions .
04	Page Keys	Press these keys to navigate to corresponding page to view additional keys.
05	Type-C Port	Connects the supplied cable to the USB Port on the host Phone. Recommended Model: FIP15G Plus, older P2X Series (without EXT.OUT)
06	EXT Port (EXT.IN)	Connects the supplied cable to the EXT.OUT on the host Phone.
07	EXT Port (EXT.OUT)	Connects the supplied cable to the EXT.IN on the next expansion module.
08	Screw hole	For fixed Phones with expansion modules.
09	Label	Display product information and certifications.

Icon Instructions



Features Icon

The icons displayed on the LCD status bar of the phone are described below:







Icons	Description	Icons	Description
	DND		Editing
	SpeedDial		Status
	Menu		Directory
	History		LDAP
	Corporate Directory		Local group
	Xml group		Xml browser
	Multicast Paging/Paing List		DTMF
	Record		URL record

	Pickup		Group pickup
	URL request		Private hold
	Voice Mail		Hot Desking





Icon Indicators (associated with Line)

Icons	Description
	Line registers successfully
	Register failed





Icon Indicators (associated with BLF/BLF List)

Icons	Description
	BLF/BLF List idle state
	BLF/BLF List ringing state
	BLF/BLF List callout state
	BLF/BLF List talking state
	BLF List call park state
	BLF/BLF List failed state

Icon Indicators (associated with call park/retrieve park)

Icons	Description
	Call Park (Park successfully; Call park idle state)
	Call Park (Park failed)
	Call Park (Call park ringing state)
	Call Park (Call park connecting)
	Retrieve Park

Icon Indicators (associated with intercom)

Icons	Description
	Intercom idle state
	Intercom ringing state
	Intercom callout/talking state
	Intercom failed state

Icon Indicators (associated with shared line)

Icons	Description
	The shared line is idle.
	The shared line is active.
	The shared line is seized.
	The shared line receives an incoming call.
	The shared line is dialing.
	The shared line conversation is placed on public hold.
	The shared line conversation is placed on public hold.
	The shared line conversation is barged in by the other shared line party.
	For a multi-party call, all the shared line parties participating in this call place the shared line conversation on hold.

LED Instructions

The P2EXP Color Expansion Module contains two types of indicators, the Ext Keys LED and the Page Keys LED.

The following description of the expansion module's indicator lights contains the following:

Topics[Page Key LED](#)[Ext Key LED](#)**Page Key LED**

LED Status	Description
Solid green	Current page.
Off	Non-current page
Fast-flashing red	The BLF monitored user receives an incoming call on the non-current page.

Ext Key LED

Ext keys are configured as Line key.

LED Status	Description
Solid green	The line is in conversation. The line is seized.
Fast-flashing red	The line receives an incoming call.
Slow-flashing red	The call is placed on hold.
Off	The line is inactive.

Ext keys are configured as BLF key.

LED Status	Description
Solid green	The monitored user is idle.
Fast-flashing red	The monitored user receives an incoming call.
Solid red	The monitored user is talking. The monitored user's conversation is placed on hold. The monitored user is dialing. The call is parked against the monitored user's phone number.
Off	The monitored user does not exist.

Installation

The P2EXP color-screen expansion module support applies to the Flyingvoice P2X series and FIP15G Plus IP Phones, next section describes how to install the P2EXP.

TIPS: IP Phones support up to three expansion modules.

Installation of Expansion Module

1. Take the P2EXP out of the package, prepare the screws and screwdrivers in the accessories.
2. Turn over the IP phone and expansion module and lay them on a flat, non-slip surface.
3. screw the 2 screws into the holes on the expansion module for connection.
4. Insert the stand of P2EXP and IP Phone separately to complete the installation.

Connecting the Expansion Module

The P2EXP supports two ways of connection, RJ12 cable and USB to Type-C cable connection. The package contains RJ12 cable/USB to Type-C cable.

Below is the introduction of the two connection methods:

1) Using RJ12 Cable

Connect the EXT.OUT Port on the host phone and the EXT.IN port on the expansion module using one RJ12 cable. If you want connect next expansion modules, connect the EXT.OUT port on the prior expansion module and the EXT.IN Port on the next expansion module using another RJ12 cable. (Connect up to 3 expansion modules to the phone)

2) Using USB to Type-C Cable

Connect the USB port on the host phone and the Type-C port on the expansion module using one supplied cable. (This way supports the connection of only one expansion module)

To connect three expansion modules, the IP Phone must be connected to a USB hub (with independent power supply). Then, expansion modules 1/2/3 should be connected to the USB hub individually.

Startup interface

When the P2EXP is powered on, the LCD screen displays a startup interface. During the loading process, the Flyingvoice logo and "Welcome Loading..." appear.

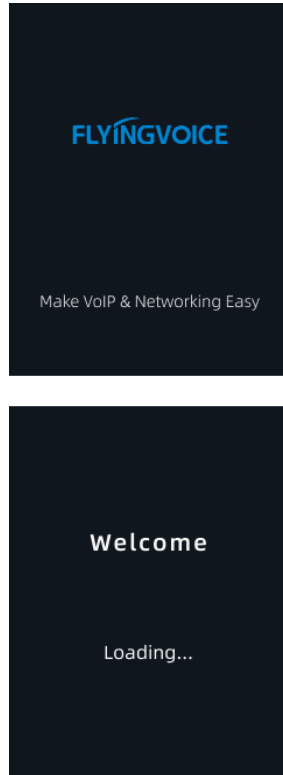

After a short time, the loading screen will disappear, and P2EXP enters the main interface.

Configure P2EXP Expansion Module

The P2EXP supports 72 DSS keys in three screen pages. Each page displays 24 DSS keys. You can press page keys to switch to the corresponding page and use your desired DSS key.

You can assign a feature to a DSS key via phone user interface. Press the desired DSS key of P2EXP for about 3 seconds, the phone LCD screen will prompt the setting of this key.

The following sections provide detailed instructions for assigning some frequently used functions to DSS keys via the web UI.

Topics

[SpeedDial](#)

[BLF](#)

[BLF List](#)

[Line](#)

[Voice Mail](#)

[Intercom](#)

[DTMF](#)
[DND](#)
[Record](#)
[URL Record](#)
[Multicast Paging](#)
[Paging List](#)
[URL Request](#)
[Pickup](#)
[Group Pickup](#)
[Call Park](#)
[Retrieve Park](#)
[Private Hold](#)
[History](#)
[Directory](#)
[Local Group](#)
[XML Group](#)
[XML Browser](#)
[LDAP](#)
[Corporate Directory](#)
[Menu](#)
[Status](#)
[Hot Desking](#)

SpeedDial

You can configure an Ext key as the SpeedDial key. You can speed up dialing the frequently used numbers by pressing the speed dial key.

Configure SpeedDial via the web interface

1. Navigate to **Phone->Ext Key**.
2. Select the desired **Ext key**, select **SpeedDial** from the **Type**.
3. Select the desired **Line** from the Line.
4. Enter the desired number you want to dial out directly in the **Value** field, (optional) enter the **Label**.
5. Click **Save & Apply**.

BLF

Busy Lamp Field (BLF) allows you to monitor the status of the pre-defined extension. You can also pick up incoming calls of the monitored extension. For more information on using the

Busy Lamp Field, contact Administration.

Configure BLF via the web interface

1. Navigate to **Phone->Ext Key**.
2. Select the desired **Ext key**, select **BLF** from the **Type**.
3. Select the desired **Line** from the Line.
4. Enter the phone number or extension you want to monitor in the **Value** field, enter the **Label**.
5. Enter the directed call pickup code in the Extension field.
6. Click **Save & Apply**.

BLF List

Busy Lamp Field (BLF) List allows you to monitor a list of users defined by your system administrator. For example, your system administrator enables BLF List, and creates a BLF List URI (e.g., BLFList@example.com) including a list of user1, user2 on the server. The BLF List keys on the IP phone can present the status of user1 and user2.

Configure BLF List via the web interface

1. Navigate to **Phone->Ext Key**.
2. Select the desired **Ext key**, select **BLF List** from the **Type**.
3. Select the desired **Line** from the Line.
4. Enter the phone number or extension you want to monitor in the **Value**, enter the **Label**.
5. Enter the directed call pickup code in the Extension field.
6. Click **Save & Apply**.

Note: Before configuring a BLF list key, make sure auto BLF list feature is disabled on the phone. For more information, contact your system administrator.

Line

You can configure a DSS key as the line key. You can press this key to enter the dialing screen when the phone is idle. You can also press this key to place a new call during an active call, and then the original call is placed on hold.

Configure Line via the web interface

1. Navigate to **Phone->Ext Key**.
2. Select the desired **Ext key**, select the desired **Line** from the **Type**.
3. (Optional) Enter the **Label**.
4. Click **Save & Apply**.

Voice Mail

Voice Mail feature allows you to leave voice messages for someone or listen to your voice mail messages on your IP phones.

This feature is set up on the server-side and not all servers support this feature.

Configure Voice Mail via the web interface

1. Navigate to **Phone -> Ext Key**.
2. Select the desired **Ext key**, select the desired **Voice Mail** from the **Type**.
3. Enter the voice mail access code in the **Value**. (e.g., *4)
4. (Optional) Enter the **Label**.

Note: For more information on using Voice Mail, refer to IP Phone's user guide.

Intercom

You can connect to the operator or the secretary more quickly by pressing the intercom key in an office environment.

Configure Intercom via the web interface

1. Navigate to **Phone->Ext Key**.
2. Select the desired Ext key, select **Intercom** from the **Type**.
3. Select the desired line from the **Line**.
4. Enter the remote extension number in the **Value**, (Optional) enter the **Label**.
5. Click **Save & Apply**.

DTMF

You can configure an Ext key as the DTMF key. If you press the DTMF key during an active call, the phone will send the pre-defined DTMF digits.

Configure DTMF via the web interface

1. Navigate to **Phone** -> **Ext Key**.
2. Select the desired Ext key, select **DTMF** from the **Type**.
3. Enter the desired DTMF feature code in the **Value**. (e.g., 1234)
4. (Optional) Enter the **Label**.
5. Click **Save & Apply**.

TIPS: You can set the DTMF feature on the phone, when calling with the intercom, press the DTMF code (e.g., 1234) to enable the intercom to act some features. For example, unlocking, alarm, emergency call, etc. For more details, please contact your system administrator.

DND

DND (Do Not Disturb) allows you can set your phone to a DND mode, in which others will not be able to call your phone.

Configure DND via the web interface:

1. Navigate to **Phone**->**Ext Key**.
2. Select the desired Ext key, select **DND** from the **Type**.
3. (Optional) Enter the **Label**.
4. Click **Save & Apply**.

Record

Call recording allows users to record calls. This usually means that the phone sends a SIP INFO message to the server that contains a specific header. URL Recording is when the phone sends an HTTP URL to the server. the server processes this information and decides to start or stop the recording. You can configure an extension key to act as a record key and then press the record key to record a call using the record method.

Configure Record via the web interface

1. Navigate to **Phone**->**Ext Key**.
2. Select the desired Ext key, select **Record** from the **Type**, (optional) enter the **Label**.
3. Click **Save & Apply**.

URL Record

You can configure an Ext key as the URL Record key. Then you can record calls using the URL record method by pressing the call record key.

Configure URL Record via the web interface

1. Navigate to **Phone->Ext Key**.
2. Select the desired Ext key, select **Record** from the **Type**, (optional) enter the **Label**.
3. Enter the **URL address** in the **Value**. (e.g., http://192.168.10.2)
4. Click **Save & Apply**.

Multicast Paging

You can configure an Ext key for Paging. Multicast paging allows you to quickly and easily announce time sensitive announcements to people within the multicast group.

Configure Multicast Paging via the web interface

1. Navigate to **Phone->Ext Key**.
2. Select the desired Ext key, select **Paging** from the **Type**, (optional) enter the **Label**.
3. Enter the **URL address** in the **Value**. (e.g., 224.0.0.1:10001)

The valid multicast IP addresses range from 224.0.0.0 to 239.255.255.255.

4. Click **Save & Apply**.

TIPS: Before using the Multicast Paging function, you should complete the paging configuration function on the phone. For more detailed information on paging, refer to the IP Phones User's Manual.

Paging List

You can configure an Ext key as a Paging List. The Paging List feature allows you to quickly and easily shout notifications to people in multiple multicast groups within the list.

Configure Paging List via the web interface

1. Navigate to **Phone->Ext Key**.
2. Select the desired **Ext Key**, select **Paging List** from the **Type**, (optional) enter the **Label**.

3. Click **Save & Apply**.

TIPS: Before using the multicast list function, you should complete the Paging List configuration function on the phone. For more detailed information, contact the administrator.

URL Request

You can configure an Ext key as a URL Request key. If you press the URL Request key, the phone sends an HTTP request to the web server.

Configure URL Request via the web interface

1. Navigate to **Phone->Ext Key**.
2. Select the desired **Ext Key**, select **Paging List** from the **Type**, (optional) enter the **Label**.
3. Enter the URL Request Address in the **Value**. (e.g., http://192.168.10.52)
4. (Optional) Enter the **Label**.
5. Click **Save & Apply**.

TIPS: You can set the DTMF feature on the phone, when calling with the intercom, press the DTMF code (e.g., 1234) to enable the intercom to act some features. For example, unlocking, alarm, emergency call, etc. For more information, please contact your system administrator.

Pickup

You can configure an Ext key as the pickup key. If you press the pickup key when the specified phone number receives an incoming call, the call will be answered on your phone.

Configure Pickup via the web interface

1. Navigate to **Phone -> Ext Key**.
2. Select the desired **Ext Key**, select **Pickup** from the **Type**.
3. Select the **Line** you want to use for pickup, (optional) enter the **Label**.
4. Enter the **call pickup code** followed by the specific extension you want to pick up calls from in the **Value** (e.g., *071001).
5. Click **Save & Apply**.

Group Pickup

You can configure an Ext key as the pickup key. If you press the pickup key when the specified phone number receives an incoming call, the call will be answered on your phone.

Configure Pickup via the web interface

1. Navigate to **Phone -> Ext Key**.
2. Select the desired **Ext Key**, select **Group Pickup** from the **Type**.
3. Select the **Line** you want to use for pickup, (optional) Enter the **Label**.
4. Enter the **call pickup code** followed by the specific extension you want to pick up calls from in the **Value** (e.g., *97).
5. Click **Save & Apply**.

Call Park

The call park feature allows you to park a call at a special extension and then retrieve it on any other phone in the system. You can configure an Ext key as the call park key. Then you can park a call at an extension by pressing the call park key. The current call is placed on hold and can be retrieved on another IP phone.

Configure Call Park via the web interface

1. Navigate to **Phone -> Ext Key**.
2. Select the desired **Ext Key**, select **Call Park** from the **Type**.
3. Select the **Line** you want to use for call park.
4. Enter the call pickup feature code in the **Value**, (optional) enter the **Label**.
5. Click **Save & Apply**.

Retrieve Park

You can configure an Ext key to Retrieve Park, which allows you to retrieve a call when you press the Retrieve Park key.

Configure Retrieve Park via the web interface

1. Navigate to **Phone->Ext Key**.
2. Select the desired Ext Key, select **Retrieve Park** from the **Type**.
3. Select the **Line** you want to use for retrieve park.

4. Enter the Retrieve Park feature code in the **Value**, (optional) enter the label.
5. Click **Save & Apply**.

Private Hold

You can configure an Ext key as the hold key. You can hold a call or retrieve a held call by pressing the hold key.

Configure Hold via the web interface

1. Navigate to **Phone->Ext Key**.
2. Select the desired Ext Key, select **Private Hold** from the **Type**, (optional) enter the **Label**.
3. Click **Save & Apply**.

History

You can configure an Ext key to History (Call logs), when you press the History key, you can quickly access all the call records (Missed, Dialed, Received, Transfer).

Configure History via the web interface

1. Navigate to **Phone->Ext Key**.
2. Select the desired Ext Key, select **History** from the **Type**.
3. Click **Save & Apply**.

Directory

You can configure an Ext key to Directory. You can press the Directory key for quick access to local directories, blacklists, remote phonebook, LDAP, and more.

Configure Directory via the web interface

1. Navigate to **Phone->Ext Key**.
2. Select the desired Ext Key, select **Directory** from the **Type**.
3. Click **Save & Apply**.

Local Group

You can configure an Ext key as a local group. When you press the Local Groups key, you can

quickly access pre-saved groups of contacts in your local directory.

Configure Local Group via the web interface

1. Navigate to **Phone->Ext Key**.
2. Select the desired Ext Key, select **Local Group** from the **Type**.
3. Select the desired contact group name from the **Line**.
4. Click **Save & Apply**.

XML Group

You can configure an Ext key as XML key. If you press the XML group key when the phone is idle, the phone automatically downloads the corresponding phonebook from the server and displays the group phonebook on the LCD screen of the phone.

Configure XML Group via the web interface

1. Navigate to **Phone->Ext Key**.
2. Select the desired Ext Key, select **XML Group** from the **Type**.
3. Select the xml group name from the **Line**, (optional) enter the **Label**.
4. Click **Save & Apply**.

XML Browser

XML browser is a simple browser feature, which is based on xml language and http/https service. Users can use tools such as PHP, JavaScript, etc., accordance with the established syntax, to generate server-side features dynamically to meet the needs of the user xml file, and then download the xml file to IP Phone by http/https, so as to realize a simple browser feature. Using XML browser, users can achieve the personalized features, such as weather information, stock information, date of inquiry, access to Office notifications sent, weather information, access to address book and so on.

Configure XML Browser via the web interface

1. Navigate to **Phone->Ext Key**.
2. Select the desired Ext Key, and select the **XML Browser** from the **Type**.
3. Enter the URL you want to set as the XML Browser in the Value (e.g.,
http://192.168.71.10/Phonebook.xml)
4. (Optional) Enter the **Label**.

5. Click **Save & Apply**.

LDAP

LDAP (Lightweight Directory Access Protocol) is an application protocol for accessing and maintaining information services of the distributed directory over an IP network. The IP phone can be configured to interface with a corporate directory server that supports LDAP.

Configure LDAP via the web interface

1. Navigate to **Phone->Ext Key**.
2. Select the desired Ext Key, and select the **LDAP** from the **Type**.
3. (Optional) Enter the **Label**.
4. Click **Save & Apply**.

TIPS: Before you can use the LDAP feature, you should complete the configuration of the LDAP feature on the phone. For more details, refer to IP Phone's User Guide or contact the administrator.

Corporate Directory

You can configure an Ext key as Corporate Directory key. You can press the key for quick access to the corporate phone book.

Configure Corporate Directory via the web interface

1. Navigate to **Phone->Ext Key**.
2. Select the desired Ext Key, and select the **CorporateDirectory** from the **Type**.
3. (Optional) Enter the **Label**.
4. Click **Save & Apply**.

TIPS: Before using the corporate directory feature, you should complete the corporate directory (UC2.x) configuration on your phone. For more details, please contact the administrator.

Menu

You can configure an Ext key as menu key. You can press the menu key for quick access to Status, Features, Directory, Messages, Basic Settings, Advanced Settings and more.

Configure Menu via the web interface

1. Navigate to **Phone->Ext Key**.
2. Select the desired Ext Key, and select the **Menu** from the **Type**.
3. (Optional) Enter the **Label**.
4. Click **Save & Apply**.

Status

You can configure an Ext key to Hot desking key. You can press the status key to quickly view network, device, Line registration, and RTP information.

Configure Status via the web interface

1. Navigate to **Phone->Ext Key**.
2. Select the desired Ext Key, and select the **Status** from the **Type**.
3. (Optional) Enter the **Label**.
4. Click **Save & Apply**.

Hot Desking

Hot Desking is regularly used in places where not all the employees are in the office at the same time, or not in the office for a very long time, which means actual personal offices would be often vacant, consuming valuable space and resources.

Hot Desking is a phone feature that allows users to login or logout an IP phone. You can configure an Ext key as the hot desking key. Press the hot desking key to delete all accounts on the IP phone, and then register your account on line 1.

Configure Hot Desking via the web interface

1. Navigate to **Phone->Ext Key**.
2. Select the desired Ext Key, and select the **Hot Desking** from the **Type**.
3. (Optional) Enter the **Label**.
4. Click **Save & Apply**.

Resetting the P2EXP Expansion Module

You can Reset the default settings for a page by logging in to the phone's web interface to access the Ext Key page, or you can clear the configuration of the P2EXP's Ext Key by resetting the host phone to the factory settings on the phone's interface.

Reset the P2EXP Expansion Module via the phone web interface

1. Navigate to **Phone->Ext Key**.
2. Select the desired Ext key page you want to clear.
3. Click on **Reset to default**, and the configuration of this page will be cleared.

Reset the P2EXP and Host phone via the Phone UI

1. Press **Menu->Advanced** (Default password: admin) ->**Reset to factory settings**
2. Select **Reset to Factory Settings** on the host phone. The LCD screen of the host phone prompts the following warning: "**Reset to factory settings?**"
3. Press the **OK** soft key on the host phone, the phone is rebooting.

The host phone and the P2EXP expansion module will be reset to factory settings successfully after startup.